

FERROXCUBE

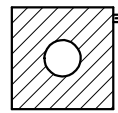

c



d

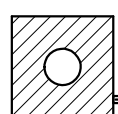

e

f

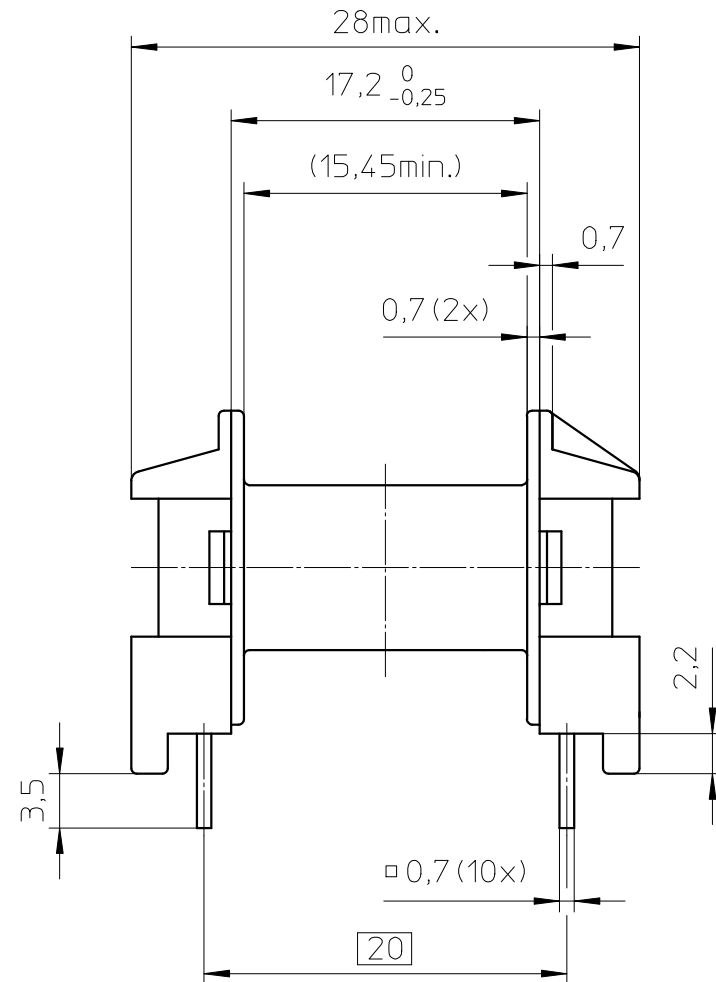
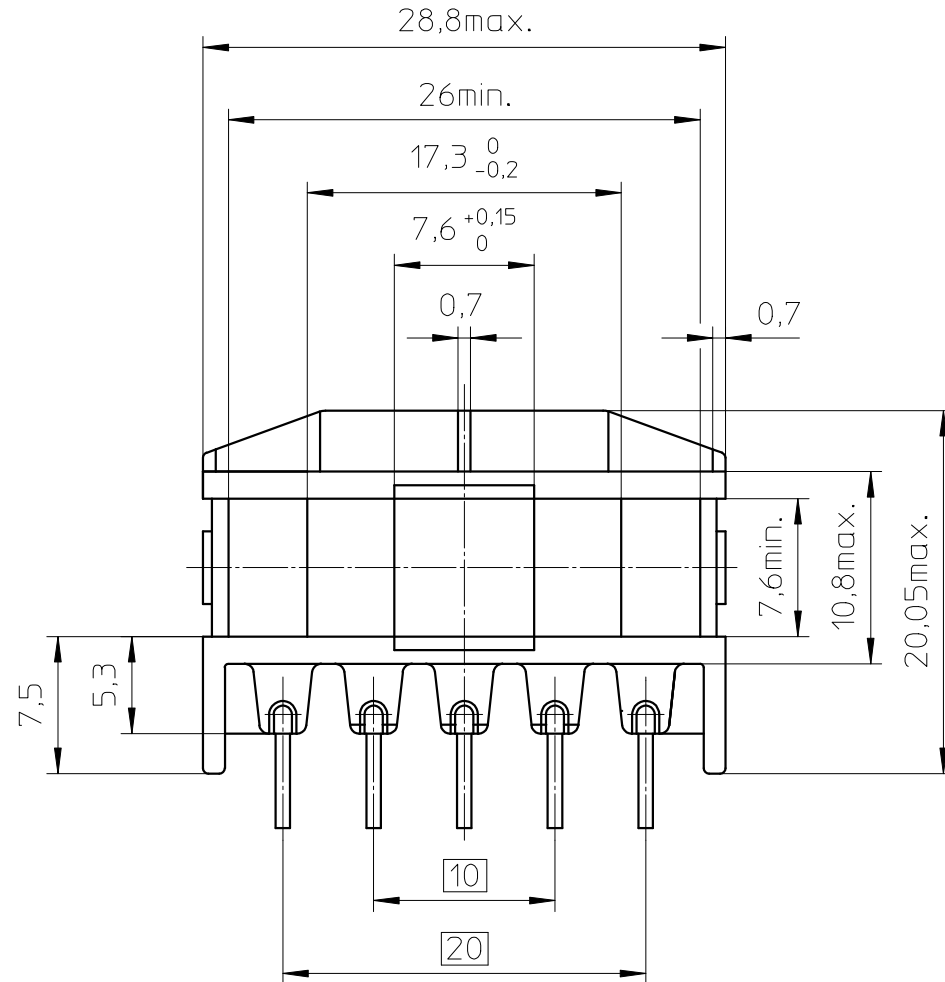
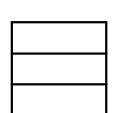

PIN ARRANGEMENT:

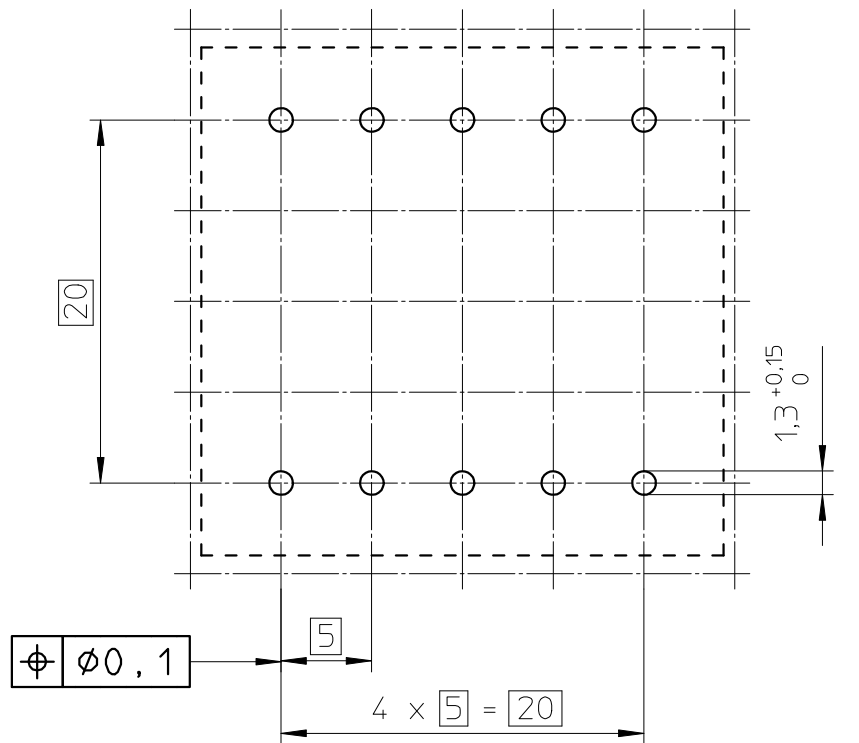
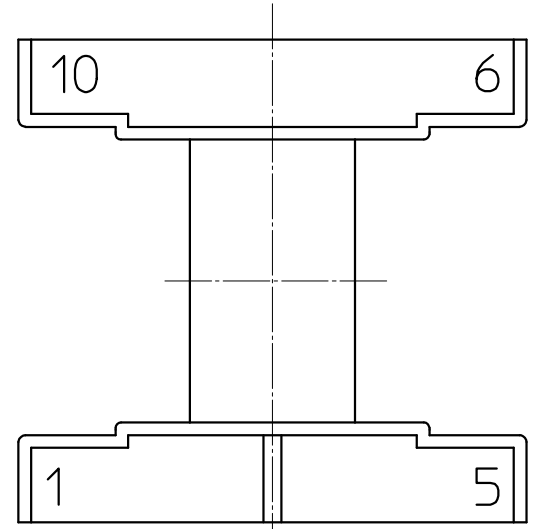

Coil former material: Valox 420SE0 (PBT), glass-reinforced.
 UL file number: E45329 - UL94V-0.
 Pin material: Copperclad steel - Sn plated.
 Max. operating temp.: acc. to IEC 60 085 class F, 155°C.
 Resistance to soldering heat: acc. to IEC 60 068-2-20 Part 2, Test Tb, method 1B, 350°C-3,5s.
 Solderability: acc. to IEC 60 068-2-20 Part 2, Test Ta, method 1, 235°C-2s.
 Min. winding area: 61,8 mm².
 Mean length of turn: 52,4 mm.

CLASS.NO.	CPH-E25/13/7-1S-10P		4322 021 00391		93-01-11
97-02-14					93-09-24
					97-02-14
					97-04-18
					04-10-05
NAME NAAM MPA	M.Veekens	SUPERS. VERV.	1	SH BL	112 - 001
CHECK CONTR.		DAT.	93-01-11	Property of Eigendom van	069
					A3
					© FERROXCUBE 2000