

General data 14-pins coaxial ETD34 coil former

PARAMETER	SPECIFICATION
Coil former material	phenolformaldehyde (PF), glass-reinforced, flame retardant in accordance with "UL 94V-0"; UL file number E41429
Pin material	copper-clad steel, tin (Sn) plated
Maximum operating temperature	180 C, "IEC 60085", class H
Resistance to soldering heat	"IEC 60068-2-20", Part 2, Test Tb, method 1B, 350 C, 3.5 s
Solderability	"IEC 60068-2-20", Part 2, Test Ta, method 1

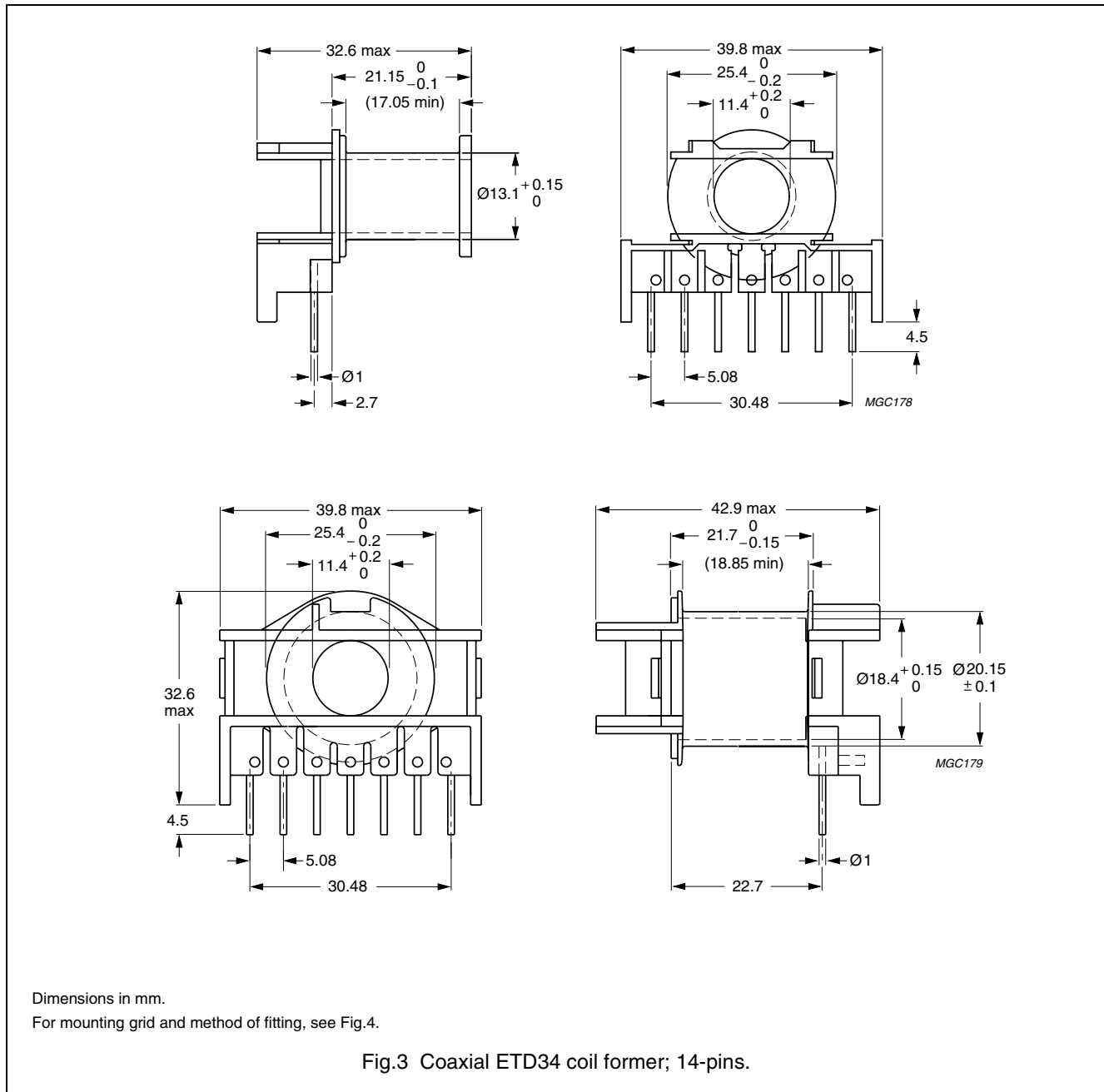

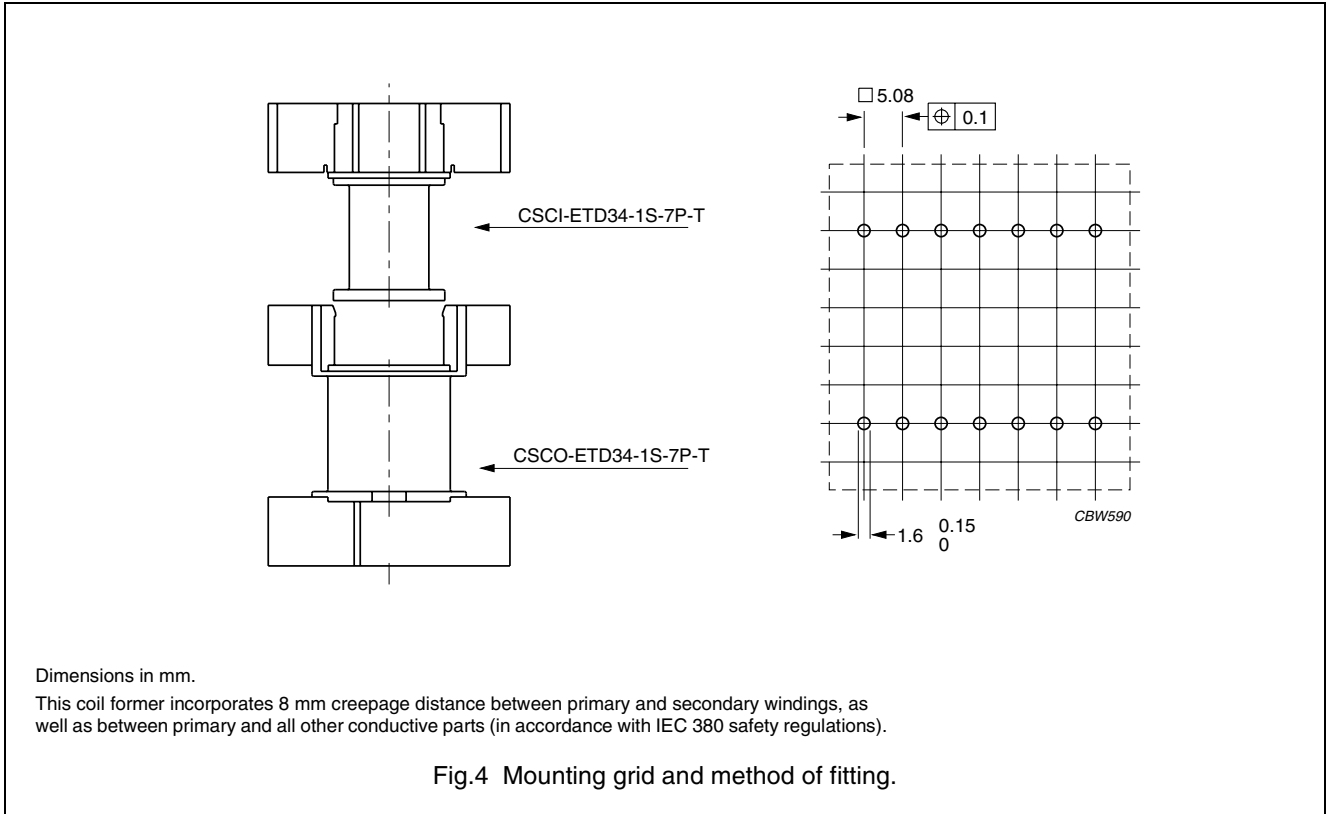

Winding data for coaxial ETD34 coil former

NUMBER OF SECTIONS	WINDING AREA (mm ²)	MINIMUM WINDING WIDTH (mm)	AVERAGE LENGTH OF TURN (mm)	TYPE NUMBER
1	42.6	17	49.4	CSCI-ETD34-1S-7P-T
1	46.6	18.9	71.4	CSCO-ETD34-1S-7P-T