

code **ST06** | project **A67-A** | release **B**



GENERAL CHARACTERISTICS

- Magnetic sensor for linear and angular reading.
- Very small size, to allow installation in narrow spaces.
- Contactless reading.
- Resolutions up to 48000 DPI.
- Status indication through LED RGBW.
- Flexible cable that allows the axial or radial output.
- Extremely easy and fast mounting of the entire measuring system, with wide alignment tolerances.
- Option: cleaning wipers to remove dirt deposits from the magnetic band, ensuring the correct functioning of the system.
- Magnetic band composed by a magnetized plastroferrite tape, with pole pitch 2.54+2.54 mm. The plastroferrite is supported by a stainless steel tape, already provided with the adhesive tape, for an easy application on the machine.
- To be used with magnetic band MP254 or MP254R (with reference indexes positioned upon request).

Cod. MME	I
Pole pitch	2.54+2.54 mm
Reference indexes	C = constant step (every 5.08 mm) R = positioned on the magnetic band
Resolution	48000 - 24000 - 12000 - 9600 - 6000 - 4800 - 3000 - 2400 - 1200 - 600 DPI
Accuracy grade	± 13 µm *
Interpolation error (SDE)	± 3.5 µm **
Unidirectional repeatability	± 0.8 µm **
Hysteresis	3 µm **
A, B and I ₀ output signals	LINE DRIVER PUSH-PULL
Vibration resistance (EN 60068-2-6)	300 m/s ² [55 ÷ 2000 Hz]
Shock resistance (EN 60068-2-27)	1000 m/s ² [11 ms]
Protection class (EN 60529)	IP 67
Operating temperature	-20 °C ÷ 75 °C
Storage temperature	-40 °C ÷ 80 °C
Relative humidity	100%
Power supply	5 ÷ 24 Vdc ± 10% ***
Current consumption without load	40 mA _{MAX}
Current consumption with load	100 mA _{MAX} (with 5 V and R = 120 Ω) 80 mA _{MAX} (with 24 V and R = 1.2 kΩ)
Electrical connections	see related table
Electrical protections	inversion of polarity and short circuits
Weight	20 g

* The declared accuracy grade of ± X µm is referred to a measuring length of 1 m.

** The error declared is subject to the respect of the alignment tolerances.

*** Warning: voltages higher than 27 V will damage the sensor.

MECHANICAL CHARACTERISTICS

- Magnetic sensor body made of die-cast metallic material.
- Possibility to fix the magnetic sensor with M3 screws or with through M2.5 screws.
- Wide alignment tolerances.

ELECTRICAL CHARACTERISTICS

- Reading through positioning sensor based on magneto resistance, with AMR effect (Magnetic Anisotropy).
- High signal stability.
- Electrical protection against inversion of power supply polarity and short circuits on output port.
- For applications where the maximum speed exceeds 1 m/s, it is necessary to use a cable suitable for continuous movements.
- **CABLE:**
Flexible cable for axial or radial output. As a standard, the sensor is supplied with the following cable:
 - 8-wire shielded cable $\phi = 4.4$ mm, PUR external sheath with low friction coefficient, oil resistant;
 - Conductors section: power supply 0.135 mm²; signals 0.08 mm².

The cable's bending radius should not be lower than 50 mm.

As a standard, the sensor is supplied with a 2-m cable.

Longer lengths are available, with the following limits:

L _{max} = 10 m	sensor cable
L _{max} = 50 m	2 m sensor cable + cable extension

Cable extensions need to have a section of at least 0.5 mm² for power supply conductors.

LINE DRIVER	PUSH-PULL	CONDUCTOR COLOR
A	A	Green
\bar{A}	NC	Orange
B	B	White
\bar{B}	NC	Light-blue
I ₀	I ₀	Brown
\bar{I}_0	NC	Yellow
+V	+V	Red
0V	0V	Blue
SCH	SCH	Shield

code **ST06** | project **A67-A** | release **B**

OUTPUT SIGNALS

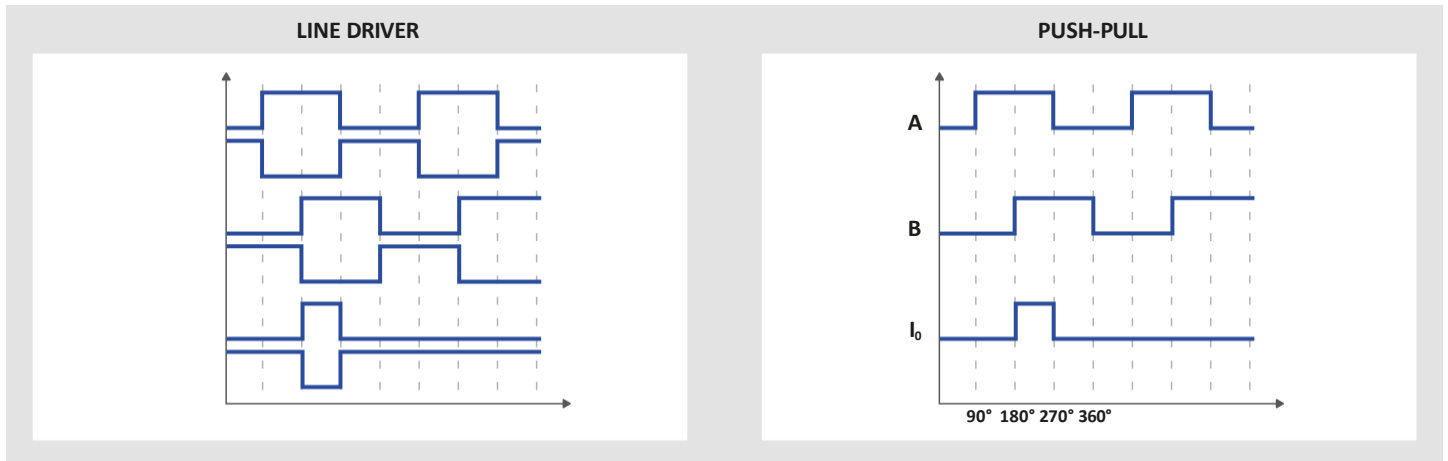

MAXIMUM SPEED

Resolution (DPI)	48000	24000	12000	9600	6000	4800	3000	2400	1200	600	Min. edge separation (μ s)
STANDARD Speed (m/s)	1.8	3.6	7.2	9.6	14.4	19.2	28.8	38.4	56.2	56.2	0.24
HIGH Speed (m/s)	3.6	7.2	14.4	19.2	30	38.4	56.2	56.2	-	-	0.12

DIMENSIONS

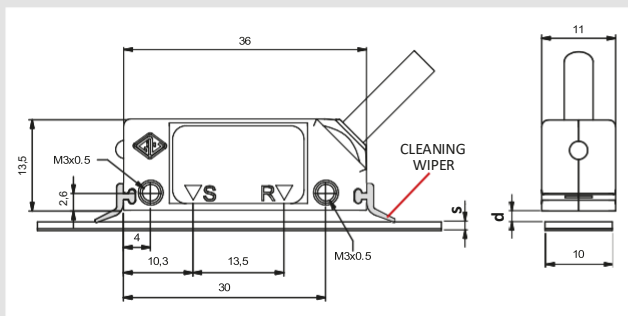

	MP254	MP254 + CV103	MP254 + SP202	MP254R	MP254R + CV103	MP254R + SP202
s (mm)	1.3	1.6	2.1	1.3	1.6	2.1
d (mm)	0.2 ÷ 1.4	1.1 _{MAX}	0.6 _{MAX}	0.3 ÷ 0.8	0.5 _{MAX}	-

s = thickness without double-sided tape. Thickness with double-sided tape + 0.1 mm.
d = distance to be maintained between sensor and surface of the magnetic band (or eventual cover/support).

ALIGNMENT TOLERANCES

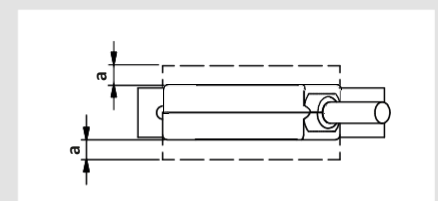
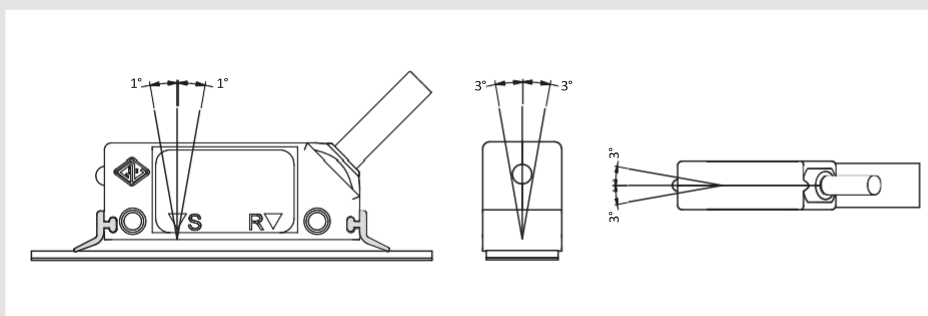

	MME lxxxC	MME lxxxR
a (mm)	1 _{MAX}	0.5 _{MAX}

a = alignment tolerance

code **ST06** | project **A67-A** | release **B**

The following graphs show tests carried out in a metrological room under controlled climatic conditions: $T = 20\text{ }^{\circ}\text{C} \pm 0.1\text{ }^{\circ}\text{C}$ and $R.H. = 45 \div 55\%$. The reference system for the comparison of position measurements is interferometric with 1 nm resolution and equipped with an environmental compensation device. The sensor is installed according to the recommended mechanical configuration at a distance of 0.5 mm from the magnetic band.

ACCURACY

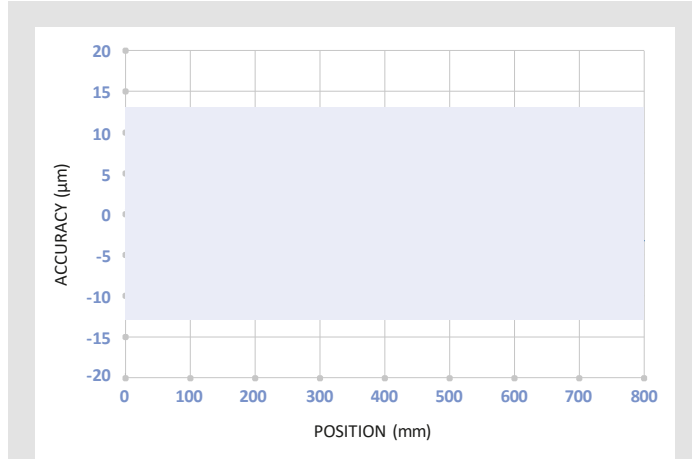

Accuracy graph: deviation between the value measured by the sensor and the value measured by the reference system.

INTERPOLATION - SDE

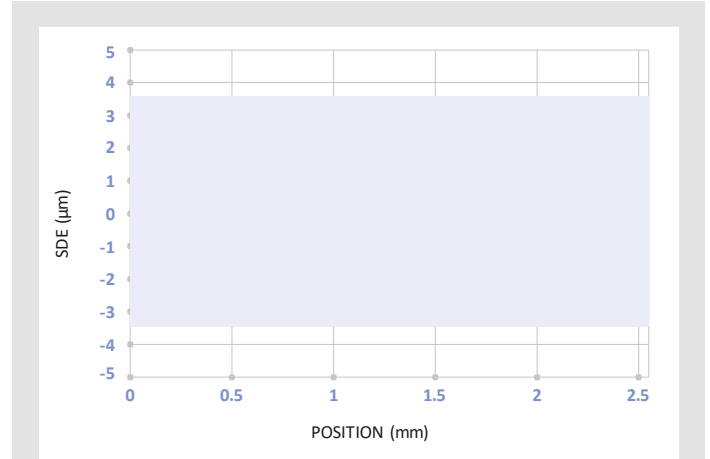

SDE (sub-division error) graph: accuracy of the interpolation device within the single pole pitch.

REPEATABILITY

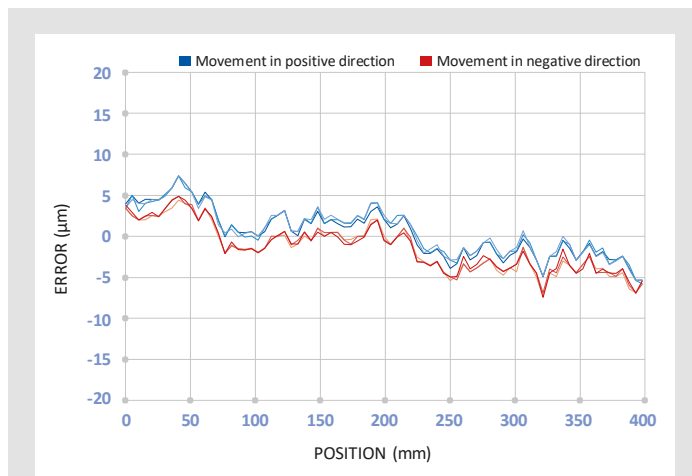

Repeatability graph obtained by carrying out the measurements several times in both directions of advancement.

- Unidirectional repeatability: measurement error detected without inverting the movement direction of the sensor.
- Hysteresis: difference in the measure due to the inversion of the sensor movement direction.

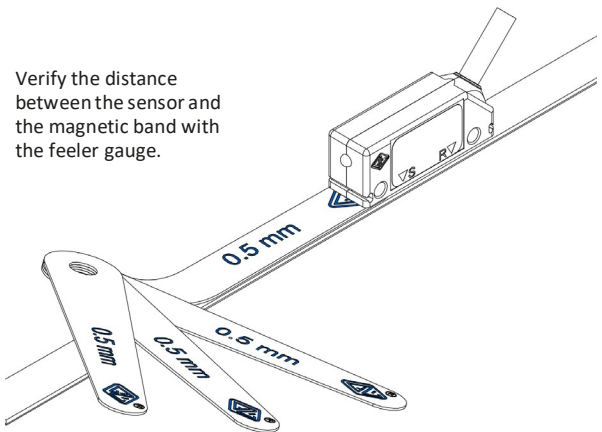

Verify the distance between the sensor and the magnetic band with the feeler gauge.

WARNING!

Avoid the direct contact with magnetized objects or tools that could damage the surface.
DO NOT TOUCH the contacts of the cable's connector to avoid electrostatic discharges (ESD) on the device.



CODICE DI ORDINAZIONE

Example MAGNETIC SENSOR **MME I 48000 C 524V L S M02/S SC**

Model	Pole pitch	Resolution	Reference indexes	Power supply	Output signals	Speed	able	Connection	Special
MME	$l = 2.54+2.54\text{ mm}$	48000 = 48000 DPI 9600 = 9600 DPI 600 = 600 DPI	C = constant step R = positioned on the magnetic band	524V = 5÷24 Vdc	L = LINE DRIVER Q = PUSH-PULL	S = standard H = high	M01 = 1 m M02 = 2 m M03 = 3 m S = PUR cable	SC = without connector Cnn = progressive	No cod. = standard SPnn = speciale nn

Without prior notice, the products may be subject to modifications that the Manufacturer reserves to introduce as deemed necessary for their improvement.

**WORLDWIDE
BRANCHES AND
SERVICE CENTERS**

Our branches in China, India and Turkey are completely independent in providing a before and after sales service and a fast and qualified technical assistance.

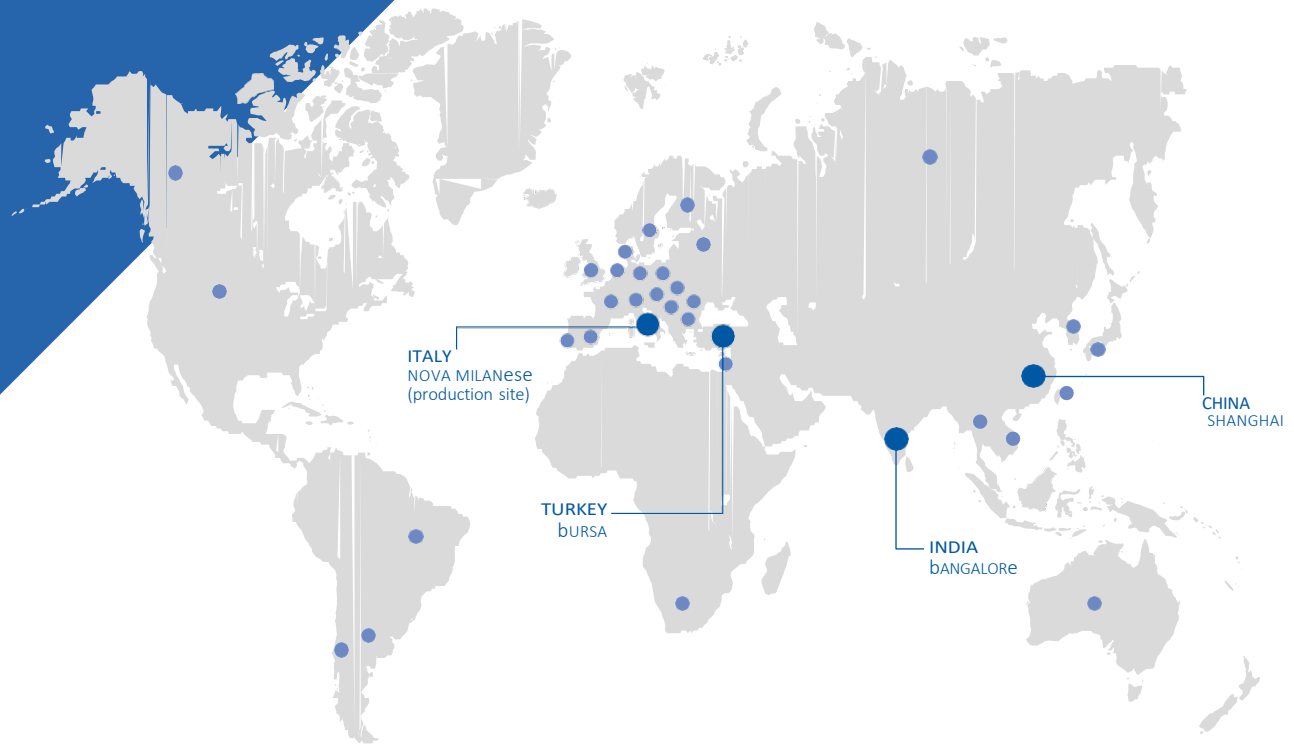

DISTRIBUTORS AND SERVICE CENTERS AROUND THE WORLD

- ARGENTINA
- AUSTRALIA
- belarus
- BRAZIL
- bulGARIA
- CANAdA
- CHILE
- CHINA
- CZECH REPUBLIC
- denMARK
- finLAND
- fRANCE
- GERMANy
- GREAT BRITAIN
- HUNGARY
- india
- ISRAel
- ITALy
- JAPAN
- POLAND
- PORTUGAL
- ROMANIA
- RUSSIA
- SLOVAKIA
- SOUTH AFRICA
- SOUTH KOREA
- SPAIN
- Sweden
- SWITZERLAND
- TAIWAN
- THAILAND
- THE NETHERLANDS
- TURKEY
- USA
- VIETNAM



Optical scales



Magnetic systems



Rotary encoders



Digital readouts



Position controllers



Megatron AG – Gewerbehau Ergolz, Wölferstrasse 5 4414 **Applications**

Füllinsdorf
Telefon: +41 (0)55 617 00 88
E-Mail: sales@megatron.ch
www.megatron.ch

- CNC machines
- Press brakes
- Traditional machines
- Automation
- Wood, glass and marble processing machines
- Renewable energies
- Special applications