

Code ST06	Project A02	Release B	Title TECHNICAL DATASHEET
---------------------	-----------------------	---------------------	-------------------------------------

OPTICAL ENCODER EN38MN

GENERAL FEATURES

- Incremental optical rotary encoder with small overall dimensions.
- Flange and body made of aluminium.
- Sealed cable output either radial or axial position.

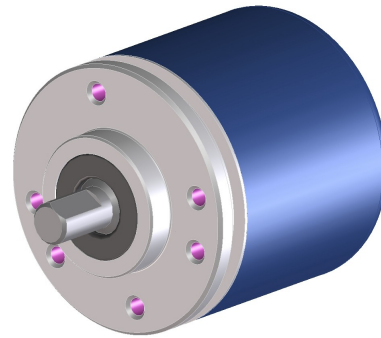

MECHANICAL AND ELECTRICAL FEATURES

<p>MECHANICAL</p> <ul style="list-style-type: none"> • Flange and body made of aluminium. • Ring for high protection. • Shaft made of stainless steel. • Ball bearings. • Fixing by no. 3 screws M3 at 120° or no. 4 screws M3 at 90°. • Centring diameter 20mm. • High rotational precision. • High protection against environmental conditions. <p>ELECTRICAL</p> <ul style="list-style-type: none"> • Protection against shortcuts. • High stability of output signals. 	Code EN38MN	PP	L5
	Pulses per revolution	from 5 to 3600 ppr	
	Max. rotating speed	momentary	8000rpm
		permanent	6000rpm
	Max. load on shaft	30 N (radial) - 30 N (axial)	
	Shaft (diameter A x length L) mm	ø6 h7 - ø8 h7	
	Protection class	IP65 (standard) * IP67 (optional)	
	Operating temperature	0 ÷ 70° C	
	Storage temperature	-20 ÷ 80° C	
	Humidity	20 ÷ 90 % (not condensed)	
	Power supply	5 ÷ 28V ± 10%	
	Current consumption at 5V	40 mA	
	Max. output current	40 mA	70 mA
	Max. frequency	120 kHz	
	Output	Push-Pull	Line Driver
	Standard length of cable	1m	
	Electrical connections	see rel. table	
	Electrical protections	inversion of power supply polarity short-circuits on output port	
Weight	80 g		

* It is important to note that shaft rotates more freely in the version with protection class IP65.

ORDERING CODE

MODEL	CABLE OUTPUT	PPR	POWER SUPPLY	SHAFT Ø	CABLE	OUTPUT	OPTIONS
EN38MN	HR	xxxxx	05V	D06	M01	L5 C	V2
	HR = radial HA = axial		05V = 5V 0528 = 5 ÷ 28V	D06 = ø6mm D08 = ø8mm	M0.5 = 0.5 m M01 = 1 m M40 = 40m _{MAX}	L5 C = LINE DRIVER PP C = PUSH-PULL	No code = standard configuration V2 = protection class IP67

Example **OPTICAL ENCODER EN38MN HR 00300 05V D06M01 L5 C V2**

Code	Project	Release	Title
ST06	A02	B	TECHNICAL DATASHEET

CABLE AND ELECTRICAL CONNECTIONS																																														
<p>Cable 8 cores $\varnothing = 4.5\text{mm}$, PVC external sheath</p> <p>Wires section:</p> <ul style="list-style-type: none"> - for power supply: 0.14mm^2 - for signals: 0.14mm^2 <p>Cable 5 cores $\varnothing = 4.1\text{mm}$, PVC external sheath</p> <p>Wires section:</p> <ul style="list-style-type: none"> - for power supply: 0.35mm^2 - for signals: 0.14mm^2 <p>NOTES: Respect a minimum bending radius of 50mm for cables.</p>	<p>PP</p> <table border="1"> <thead> <tr> <th>SIGNAL</th> <th>WIRE COLOUR</th> </tr> </thead> <tbody> <tr><td>A</td><td>Green</td></tr> <tr><td>B</td><td>White</td></tr> <tr><td>Z</td><td>Brown</td></tr> <tr><td></td><td></td></tr> <tr><td></td><td></td></tr> <tr><td></td><td></td></tr> <tr><td></td><td></td></tr> <tr><td>V+</td><td>Red</td></tr> <tr><td>GND</td><td>Blue</td></tr> <tr><td>\perp</td><td>Shield</td></tr> </tbody> </table>		SIGNAL	WIRE COLOUR	A	Green	B	White	Z	Brown									V+	Red	GND	Blue	\perp	Shield	<p>L5</p> <table border="1"> <thead> <tr> <th>SIGNAL</th> <th>WIRE COLOUR</th> </tr> </thead> <tbody> <tr><td>A</td><td>Green</td></tr> <tr><td>B</td><td>White</td></tr> <tr><td>Z</td><td>Brown</td></tr> <tr><td></td><td>Orange</td></tr> <tr><td></td><td>Light Blue</td></tr> <tr><td></td><td>Yellow</td></tr> <tr><td>V+</td><td>Red</td></tr> <tr><td>GND</td><td>Blue</td></tr> <tr><td>\perp</td><td>Shield</td></tr> </tbody> </table>		SIGNAL	WIRE COLOUR	A	Green	B	White	Z	Brown		Orange		Light Blue		Yellow	V+	Red	GND	Blue	\perp	Shield
	SIGNAL	WIRE COLOUR																																												
A	Green																																													
B	White																																													
Z	Brown																																													
V+	Red																																													
GND	Blue																																													
\perp	Shield																																													
SIGNAL	WIRE COLOUR																																													
A	Green																																													
B	White																																													
Z	Brown																																													
	Orange																																													
	Light Blue																																													
	Yellow																																													
V+	Red																																													
GND	Blue																																													
\perp	Shield																																													
<p>N. C. = Wire not connected</p>																																														

SHIELDED CABLE

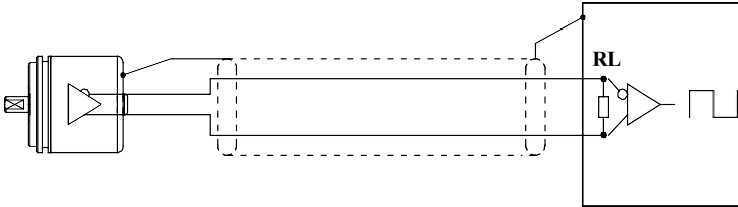

LINE-DRIVER CONNECTION	
POWER SUPPLY	RL
5V	120 Ω
12V	330 Ω
24V	1000 Ω

In case of cable extension, ensure the electrical connection between the body of connectors.

DIMENSIONS AND RECOMMENDED FIXING

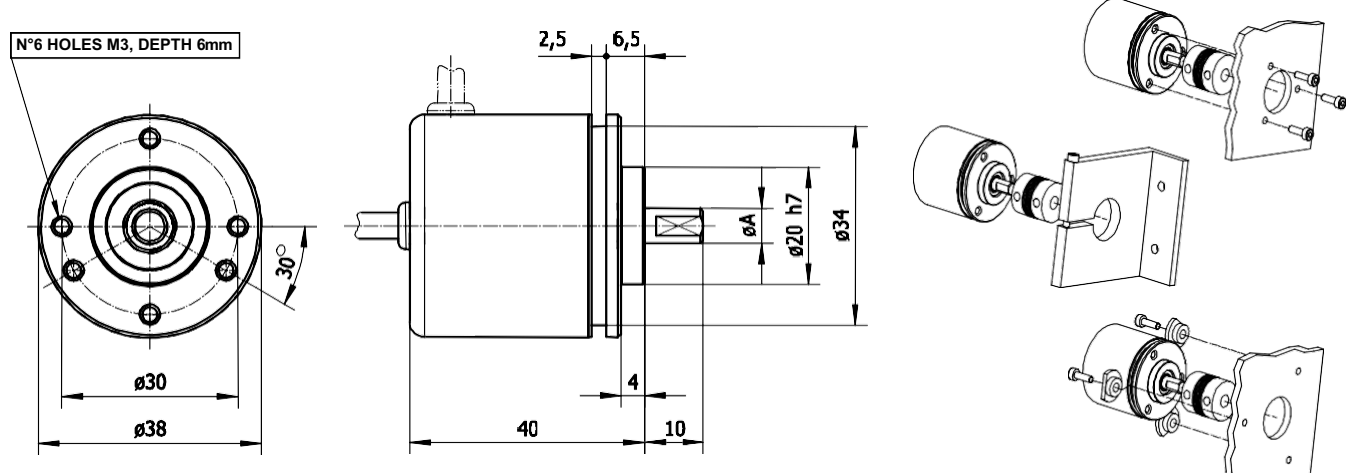

N°6 HOLES M3, DEPTH 6mm

- Use an elastic coupling for shaft junction.
- For fixing through brackets, drill on the mounting surface no. 3 holes M4 on a diameter of 50mm.

WHAT TO AVOID

- Any type of mechanical working (cut, drill, mill, etc.)
- Any modification either on the body or on the shaft of the encoder
- Any kind of bad usage
- External hits or stresses

